

# SHIP IT!

A Game For the Piecepack and Dominos

Version 1.6, November 2004, by Stephen and Michael Schoessow

Copyright, November 2004

2-4 Players

60-90 minutes

These rules may be freely copied and distributed provided the authors are credited or this header is left in place.

## Required Bits

1 standard piecepack

1 set of standard 2"X1" double-6 dominoes

## Introduction

The time is the late 1800's. Big Industry is booming in America: railroading, mining, timber, and manufacturing. The players represent barons of industry, developing resources, building infrastructure, and shipping raw materials and goods for big profits. Players strive to transport the resources they control over the developing transportation networks they are helping to build, affecting markets to their advantage and beating out opponents with critical deliveries.

## Setup

Each player is represented by a color, red, green, blue, or black. The game for three or four players is described in the body of the rules. A 2-player variant is described at the end of the rules. Players must choose their colors before the board is constructed.

Turn all the piecepack tiles suit-side-down and shuffle them, or place them in an opaque bag and mix them thoroughly. Draw tiles one at a time and place them to form an array of cities. Place the first tile in the upper left-hand corner of the playing area. Do not change the orientation of the tiles when placing them. *It is important that tile orientation be random.* Starting on the immediate right of the first tile, and going clockwise, subsequent tiles drawn are used to start forming a 2x2 square of tiles *until a tile is drawn of a color already represented in that city, or until the present city contains three tiles.* When either of these occurs, a new city is started below the first one. The first tile of the new city is placed directly below the last tile of the previous city, spaced *one tile width away*. Then once again, new tiles are added to the tile, starting another 2x2 square of tiles, going around in a clockwise direction until a tile is drawn of a color already represented or the new city contains three tiles. After the third city is formed, a new column is started, *one tile width to the right of the first column.* When the tiles are all placed, there will be either three or four columns, and typically the number of cities will be ten or eleven, occasionally nine or twelve, and only rarely anything else. Figure 1 illustrates the tile placement in a typical game setup. In this case there are eleven cities. The separate tiles of a multi-tile city are called city zones.

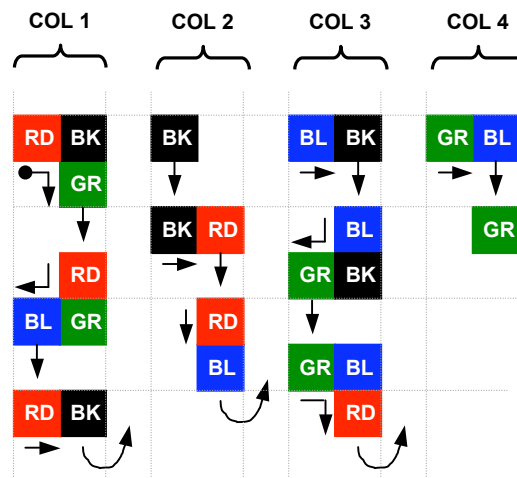

Figure 1. Example Board Set-up

Set aside the four null coins. They will be used for score keeping. Turn all the remaining coins suit-side-up and shuffle them. Then, without turning them over, distribute them among the tiles, one coin per tile, **skipping the ace tiles**. Place coins on tiles in the same order in which the tiles were placed, sticking to the coin color order: red, green, blue, black.

**Example:** The first tile placed receives a red coin, the second tile placed receives a green coin, the third tile a blue coin, and the fourth a black coin. Then the process repeats, with the fifth tile receiving a red coin and so on until all the coins are placed.

The coins represent raw materials or goods (freight) to be shipped, with the color corresponding to the player who may ship it.

Place the four pawns on their color-matched ace tiles. The pawns indicate the *current* four shipping hubs.

Place the four dice, suit icon up (die orientation has no effect on game play; the suit icons just identify player ownership), on their color-matched null tiles. The dice represent Commerce Department officials over whom players have influence. A player's official can streamline shipping for the player while complicating it for competitors.

Turn all the dominoes over and shuffle them, forming a draw pool. Dominoes represent transportation links between cities.

Print out the scoring track from the end of the rules. Players use the null coins of their color to keep track of their profits on the scoring track. The track has 100 spaces, numbered 1-100. Whenever a player scores, he places his null coin suit side up, onto the numbered space matching his present score. If a player's score exceeds 100, he starts his coin over on the scoring track and at the end of the game adds 100 points to the score indicated by his null coin on the track.

### **Object of the Game**

Players work to move their freight from its starting tile locations to one of the four shipment hubs. Then, when a major shipment occurs from one of these locations, all players who have freight warehoused there will make a profit. At the end of the game, the player who has reaped the highest profits wins.

### **Game Play**

The red player starts the game and play then moves clockwise around the table. Players start their turns with *8 action points*. These may be used to build transport links (place dominoes), move officials (move dice over dominoes and onto or across tiles), and move freight (move coins over dominoes and onto or across tiles). Players are not required to use all of their action points during a turn but action points may not be saved for use during future turns; **points not used are lost**.

Players earn profits when major shipments occur. These occur at the locations where pawns reside (the shipping hubs) when a sufficient amount of freight has been delivered to them.

Player turns consist of four phases:

- 1) Plan and pay for transport link construction
- 2) Build the paid-for transportation link(s)
- 3) Move officials
- 4) Move freight

All phases are optional, but **actions may only be taken in the order indicated**. Once a player has completed all the phases he wishes to and can afford, it is the next player's turn.

#### **1) Plan and pay for transport link construction**

Dominoes represent transport network links and players may purchase as many as they can afford each turn. Each link (domino) costs 1 action point. A link is purchased by picking a domino

from the pool of dominoes and turning it over. Late in the game, it is common for the pool of dominoes to become empty, with all the dominoes in use as transport links on the board. When this happens (and **only** when this happens), a player may remove **one** domino from the board each turn, for a cost of 1 action point. However, not all dominoes are eligible for removing; *it must be possible to slide the domino out of the board, in a **single straight line**, without disturbing any other dominoes or tiles.* Also, the domino may not be holding any pawns, coins, or dice. If there are no dominoes that meet all these criteria, then a domino may not be removed that turn. Dominoes may only be removed from the board at times when the pool is empty.

## **2) Build the paid-for transportation link(s)**

All links paid for in phase 1 **must** be built in phase 2. To build a link it is placed on the board such that at least one of its ends or half of one of its sides is immediately adjacent to a tile or another domino. There is no cost in action points for placing a link.

## **3) Move officials**

Officials are represented by dice. Officials may be moved at a cost of 1 action point per space moved. Each half-domino constitutes 1 space. Tiles moved onto or off of from dominoes also constitute spaces. A tile-to-tile movement is also considered 1 space. When on dominoes, movement may be lengthwise along a domino or sideways from one domino to another. At no time may gaps (where there is no domino or tile) be traversed.

## **4) Move freight**

Freight moves differently than officials. Coins represent freight and players in a 4-player game may only move freight of their own color (suit). Note that, in general, players do not know the value of the freight they are moving since all freight tokens available for shipment are number-side-down, and may not be peeked at. In the 3-player game, players may also move freight of the un-owned suit in addition to moving their own freight. To move freight, an initial cost of 1 action point must be paid, per load of freight moved. Then a *pip-stop* number must be chosen and paid for. **The pip-stop sets the domino pip number and the tile number over which a freight shipment may not pass.**

**Example:** If the pip-stop is 4, then freight may pass over any number of adjacent half-dominoes until it comes to one with four or more pips; it must stop **on** that one.

**The highest allowable pip-stop number is 6.** This means that a freight shipment may never pass a 6-pip half-domino and continue on during the same turn but must stop on it. Tile numbers work in the same fashion as half-domino pip numbers, when passing from a domino onto a tile or from tile to tile. Null tiles are counted as zeroes and aces are counted as 1's. The cost in action points for setting a pip-stop number is equal to the pip-stop number. Note that, even with a pip-stop of zero (free), freight may always be moved 1 space. Players may move as much freight as they can afford during a turn. The pip-stop number need only be paid for once and then applies to all freight movement that turn, but an initial cost of 1 action point must be paid for **each** piece of freight moved.

No more than one load of freight may be setting on any given half domino at a time. The freight marker covers the pip pattern and a freight-occupied space becomes a 0-pip space for other freight movement and the movement of officials. In other words, a half domino that is holding a load of freight looks like a blank half domino to other freight loads and to officials, but they may not stop there.

City zones (tiles) may hold any number of officials and loads of freight, and the number of the city zone always is the number printed on the tile. Players should try to place pawns, coins, and dice on tiles such that the tile number and suit tick remain visible.

**A city zone may only be moved onto or off of from transport links at the location of the suit tick in one corner of the city zone.** There is no such restriction regarding movement from one city zone directly to another. This applies to the movement of both officials and freight.

Figure 2 shows a small portion of a typical board layout, including two cities, during a game. It illustrates the positions of city zone tiles, some transport links, freight, officials, a shipping hub, and so on.

The small solid-color squares represent dice (commerce officials). The solid green circular spot is the green pawn (a shipping hub). The color outline circles are coins (loads of freight waiting to be moved to shipping hubs). The RD, BL, GR, and BK designations on the tiles indicate tile color (suit), for those who are seeing these instructions in mono-color, and also illustrate the positions of the suit ticks in the corners of the tiles.

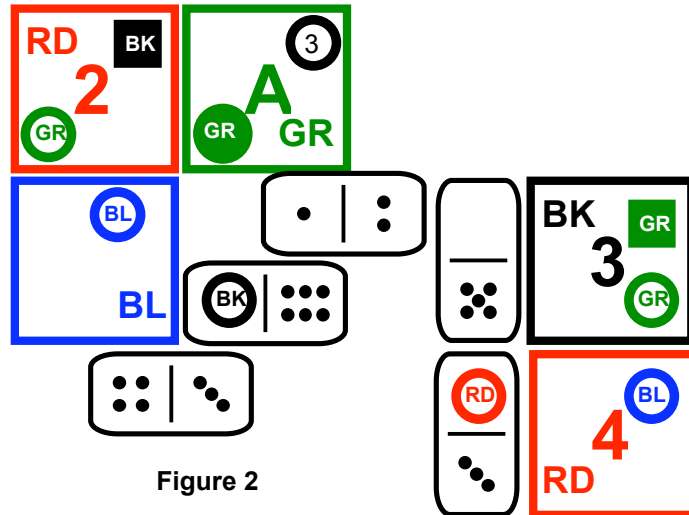

Figure 2

**Example:** In figure 2 the red player has a load of freight setting on the transport link just to the left of the red 4 city zone. He could move this freight to the shipping hub on the green ace city zone for a cost of seven action points. One action point must be spent to facilitate moving a load of freight, and six more action points will set the pip-stop to 6, allowing the freight to be moved north across the 5/0 link, then to the left across the 2/1 link, and then north again onto the shipping hub. Note that the shipping hub is entered at the corner where its suit tick resides. The freight could have been moved more economically however, for a total cost of only six action points instead of seven; with a pip-stop of five, the freight could move south one space, then to the right onto the red 4 city zone (note that the city zone may only be entered from the transport link at its lower left-hand corner, where the suit tick is), then north onto the black 3 city zone, then left, across the suit tick onto the blank transport link space, left again across the 2/1 transport link, and north onto the shipping hub.

### Warehousing, Shipment, and Profits

When freight is moved onto any tile where a pawn resides (i.e., a shipping hub), it is warehoused. Note that freight may pass over a shipping hub to stop somewhere else, but if it ends its movement on a hub, the freight **must** be warehoused. Freight is warehoused by turning the coin over so it is number-side-up.

When the sum of the coin numbers plus the tile number at a shipping hub equals or exceeds 8, shipment from that hub takes place. Normal game play immediately stops and three things occur:

- Players participating in the shipment receive profit points and, in some cases, bonuses.
- The hub marker (pawn) is moved to a new location, identifying a new shipment hub.
- Shipped freight is redistributed.

All three of these are completed in the order shown before the active player completes his turn (assuming he has action points yet remaining and wishes to use them) or the next player begins his turn.

- Each player receives profit points equal to the coin number plus twice the tile number, for each of **his own color** coins that are included in the shipment. Many shipments will

include freight owned by more than one player, and these players all record their profit points immediately, by appropriately moving their counters on the scoring track. The player who triggered the shipment receives a bonus; his profit is doubled. When a player triggers a shipment at a tile of his own color (suit), he receives an additional bonus of 8 profit points. In the 3-player game, profit points are not recorded for shipment of freight of the un-owned color.

- b) The hub marker is moved to the next higher numbered tile of the same suit.
- c) When shipment occurs, the player who triggered it takes one of his coins (player's choice which one if he has more than one coin there), that was part of the shipment, off the board permanently and it becomes an action point chit for him. This action is mandatory if the shipment contains one or more of his coins. If the shipment does not include any of his coins (as could occur in a 3-player game when the shipment is triggered by delivery of freight of the un-owned color), he does not do this. Players usually earn an additional action point chit each time they trigger a shipment, and these chits remain active throughout the remainder of the game, adding to the number of action points they have available each turn. **Chits are always worth 1 action point each.** The remaining coins of the shipment are then redistributed on the board. The player who triggered the shipment shakes them in his hands (as one would shake dice between closed hands), and then, picking them one at a time randomly out of his fist, distributes them, suit-side up, to the **lower** number tiles of the same suit that the shipping hub was, in descending number order, wrapping if necessary.

**Examples:** After shipment from an ace hub, all coins are moved to the null tile of the hub suit, since that is the only lower number tile of that suit. After shipment from a 2 hub, if there are three coins, they are distributed to the ace and null tiles of the hub suit in the order, ace, null, ace. After a shipment from a 4 hub, if there are three coins, they are distributed to the 3, 2, and ace tiles of that suit, etc. Although the coins are always picked randomly out of the player's fist, he may look at the numbers before placing them. Thus the player doing the redistribution gains a small advantage in knowledge in cases where there is more than one coin of the same suit to be redistributed.

Note: shipments from hubs may be triggered in ways other than by making freight deliveries. This will be covered in the section on Commerce Officials.

Sometimes, when the hub indicator pawn is moved, the new tile will already hold one or more loads of freight. These are immediately warehoused by turning the coins number-side-up. If, as a result of this, the sum of the coin numbers plus the tile number already equals or exceeds 8, shipment immediately occurs from the new hub. Profits are recorded, the hub marker is once again moved to the next higher numbered tile of the same suit, and the coins are redistributed, all as described in a), b), and c) above. Any bonuses for triggering the shipment in such a case go to the player who triggered the previous shipment. Astute players will anticipate such circumstances and play accordingly.

### **Commerce Officials**

The four dice represent four commerce officials. Each official is somewhat corrupt and, as such, shows favor to freight movements of his own suit. When an official is setting on a half-domino, that half-domino becomes a zero (i.e., blank) for freight of his own suit and for all other officials, **but it also becomes impassible for freight of all other suits** (freight of other suits may not land on nor pass the space). In addition, the *region* the official is in becomes inaccessible to freight of other suits (but not for other officials) unless their own officials are also within that region; other players' freight may neither pass through nor stop within the region. Thus, a player's official restricts the movement of other players' freight but not of other officials. *A region comprises all the half-dominos that could be moved to without crossing a domino centerline or moving onto a tile.* The only ways a player may counter this are to build new transport links around the blocked region if necessary, or to move his own official into the blocked region. In the latter case, his freight still may not pass through the particular half-domino space that the other official is setting on but the remainder of the region is no longer blocked.

When an official moves into a *region* containing a space already occupied by an opposing freight load, that freight load is immediately frozen until either the official moves out of the region or until an official the same suit as the freight load moves into the region.

Officials can not only hinder the opposing players; they can also grease the skids of their patrons. When a player's official is moved onto a shipping hub, all of the player's coins on that hub are doubled in their number values, with all that this implies. Opposing player's coins are not affected.

**Example:** If a player has a 3-coin warehoused at a shipping hub and he moves his official onto the hub, his coin immediately becomes a 6-coin. This increase may trigger shipment from the hub and, if it does, the usual bonus(es) for this apply. His scoring of profit points is also based upon the coin being a 6 rather than a 3. Lastly, one of the player's coins on the hub becomes an action point chit (for triggering the shipment).

**Example:** Figure 2, a couple pages back, can be used to illustrate the offensive advantages of commerce official. Black can move his official one space to the right, onto the shipping hub for a cost of 1 action point. His official doubles the value of his 3 coin already there to 6. The total for the hub is then already 7 (1 because it's an ace tile, plus 6 for the doubled 3 coin makes a total of 7). This means that any additional freight brought to the hub is sure to bring the total to 8 or more, triggering shipment. Black continues his turn by paying 1 action point to facilitate movement of his freight load, plus 3 more action points to set his pip-stop to 3. He moves his freight to the left onto the blue null city zone, then north onto the red 2 and from there, right, onto the hub, triggering shipment and receiving the bonus for doing so, plus earning the profit for shipping the two loads of double value freight; this is a lucrative turn for Black, and he still has action points remaining.

**Example:** Three commerce officials are shown in figure 3 to the right. The most interesting of these is the green official because he occupies a *region* comprising four spaces, which are shown shaded in the figure. Note that the region is bounded by domino centerlines and by tiles. No red, blue, or black freight may enter this region. For example, Black's freight load setting just to the right of the blue null city zone could not move to the right, toward the black 3 city zone, because it is denied access to the shaded region, which is occupied, and therefore controlled, by Green. Only green freight may move through this region. Black could fix this problem by moving his own official south from the green ace city zone onto the 6-pip space on the transport link to the south. Then the shaded region would be open to both Green and Black but still not to Red or Blue. The cost to Black for this movement would be 1 action point because his official would have moved one space.

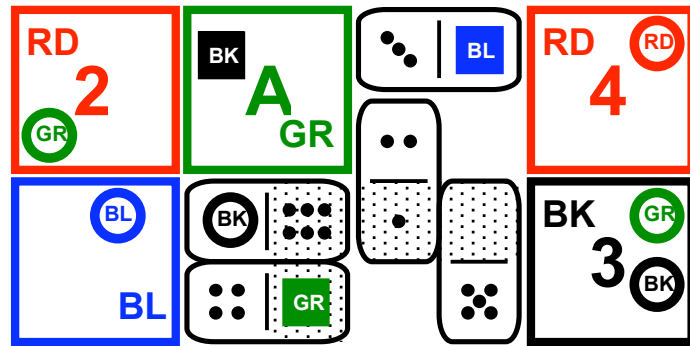

Figure 3

### Game End and Winning

When shipment is triggered from a hub on a 5 city zone, the profit point counters on the scoring track are moved as necessary, and then the hub marker is moved off the board and out of the game. When a second hub maker is taken out of the game, the game is over. The player with the highest total number of profit points wins.

## **2-Player Variant**

The 2-player version is very similar to the 4-player game except each player plays two colors. Action point chits may not be shared between the colors. Turn order is such that turns alternate between the players. Players keep separate scores for the two colors they each play. At the end of the game, **each player counts only the lower of his two scores**. The player whose lower score is higher than the other player's lower score wins the game.

## **Author Contribution Breakdown**

Ship It! Was co-designed by Michael and Stephen Schoessow. In accordance with the rules of the 6<sup>th</sup> piecepack game design competition, the specific contribution breakdown is listed:

Game concept and use of dominoes as links: Steve

Name of the game: Mike

General theme outline: Steve

Theme development: Mike

Action point system: Mike, but action costs jointly dialed in during play-testing

Movement mechanic (pip-stop number scheme): Steve

Shipping hub re-location system: Mike

Use of tile suit pips to limit city access points: Steve

City layout algorithm: Steve

Commerce official idea: proposed by Steve; named by Mike; developed jointly

Freight distribution and redistribution schemes: Mike

Action point chits: Mike

Scoring algorithm: jointly developed and dialed in

Rules text: Mike

Rules figures: Steve

Ship It! Was completed in June 2004 and submitted to the 6<sup>th</sup> piecepack game design competition as version 1.3. Following the close of the competition and the receiving of comments from the judge, the rules were revised (version 1.6, November 2004) in numerous minor ways to improve clarity. Also, a new scoring track was designed and a more detailed breakdown of author contributions was included. The authors would like to thank Clark Rodeffer for his helpful comments and suggestions regarding rules clarity.

## SCORING TRACK

1	2	3	4	5	6	7	8	9	10
11	12	13	14	15	16	17	18	19	20
21	22	23	24	25	26	27	28	29	30
31	32	33	34	35	36	37	38	39	40
41	42	43	44	45	46	47	48	49	50
51	52	53	54	55	56	57	58	59	60
61	62	63	64	65	66	67	68	69	70
71	72	73	74	75	76	77	78	79	80
81	82	83	84	85	86	87	88	89	90
91	92	93	94	95	96	97	98	99	100